

Short-Latency Vergence Eye Movements Induced by Radial Optic Flow in Humans: Dependence on Ambient Vergence Level

D.-S. YANG, E. J. FITZGIBBON, AND F. A. MILES

Laboratory of Sensorimotor Research, National Eye Institute, National Institutes of Health, Bethesda, Maryland 20892

Yang, D.-S., E. J. Fitzgibbon, and F. A. Miles. Short-latency vergence eye movements induced by radial optic flow in humans: dependence on ambient vergence level. *J. Neurophysiol.* 81: 945–949, 1999. Radial patterns of optic flow, such as those experienced by moving observers who look in the direction of heading, evoke vergence eye movements at short latency. We have investigated the dependence of these responses on the ambient vergence level. Human subjects faced a large tangent screen onto which two identical random-dot patterns were back-projected. A system of crossed polarizers ensured that each eye saw only one of the patterns, with mirror galvanometers to control the horizontal positions of the images and hence the vergence angle between the two eyes. After converging the subject's eyes at one of several distances ranging from 16.7 cm to infinity, both patterns were replaced with new ones (using a system of shutters and two additional projectors) so as to simulate the radial flow associated with a sudden 4% change in viewing distance with the focus of expansion/contraction imaged in or very near both foveas. Radial-flow steps induced transient vergence at latencies of 80–100 ms, expansions causing increases in convergence and contractions the converse. Based on the change in vergence 90–140 ms after the onset of the steps, responses were proportional to the preexisting vergence angle (and hence would be expected to be inversely proportional to viewing distance under normal conditions). We suggest that this property assists the observer who wants to fixate ahead while passing through a visually cluttered area (e.g., a forest) and so wants to avoid making vergence responses to the optic flow created by the nearby objects in the periphery.

INTRODUCTION

As observers move through the environment they experience a radial pattern of optic flow. Recent experiments by Busetini et al. (1997) have shown that such visual stimuli can elicit vergence eye movements in human subjects at very short latencies (~80 ms), even when seen monocularly. Centrifugal (expanding) flow, which signals forward motion of the observer, increased the vergence angle between the two eyes, and centripetal (contracting) flow had the converse effect. Such eye movements are appropriate insofar as the vergence angle must change to keep both eyes aligned on the object of regard in the scene ahead. However, the geometry of this situation is such that the required vergence angle for binocular alignment is inversely proportional to the viewing distance and, as the observer moves forwards or backwards, this vergence angle must change at a rate that is

inversely proportional to the square of the viewing distance.¹ This raises a potential problem when the observer moves through a cluttered environment, such as a forest, for example: any convergence resulting from the optic flow created by the nearby trees would be inappropriate if the observer is trying to fixate something far ahead. Here we report that the vergence responses induced by a given step of radial flow are a linear function of the vergence angle at the time the flow stimulus is applied with monocular as well as binocular viewing. This would mean that under normal conditions vergence induced by radial flow would be attenuated with distant viewing, an effect that would help to reduce the impact of nearby clutter in the scene as we look ahead. We conclude that this attenuation must result from the modulation of transmission within central pathways and suggest that it occurs in pathways that are shared with translational vestibulo-ocular reflexes that operate in synergy with radial-flow vergence.

METHODS

The eye movements evoked by radial flow steps were recorded from three adult human subjects. Two of the subjects were authors of this paper (*DY*, *FM*), and the third (*MB*) was unaware of the purpose of the experiment. The presentation of stimuli, and the acquisition, display, and storage of data were controlled by a PC with the use of a Real-time EXperimentation software package (REX) developed by Hays et al. (1982). The horizontal and vertical positions of both eyes were recorded with an electromagnetic induction technique with the use of scleral search coils embedded in silastin rings as previously described (Busettini et al. 1994).

The subject sat facing a translucent tangent screen (fixed distance, 33.3 cm; subtense, 85° × 85°) onto which two identical, overlapping patterns were back-projected. Orthogonal polarizing filters in the two projection paths and matching filters in front of each eye ensured that each pattern was visible to only one eye as previously described (Busettini et al. 1996). Pairs of mirror galvanometers (General Scanning, M3-S with vector tuning) positioned in each of the two light paths in an X/Y configuration were used to control the horizontal and vertical positions of the two images. The patterns consisted of white circular dots (each subtending 1° at screen center) randomly distributed on a black background (50% coverage). At the beginning of each trial, the two patterns on the screen were positioned in register creating a single binocular image in the plane of the screen 33.3 cm away. The two patterns then moved horizontally in opposite directions at 3°/s so

The costs of publication of this article were defrayed in part by the payment of page charges. The article must therefore be hereby marked "advertisement" in accordance with 18 U.S.C. Section 1734 solely to indicate this fact.

¹Assume an observer with interpupillary separation S fixating an object of regard at a distance D . As the observer moves a distance ΔD toward the object of regard, the required rate of increase in the vergence angle is approximated by $[(S/(D - \Delta D)) - (S/D)]$, which simplifies in the limit to $S\Delta D/D^2$.

as to induce the subject to converge at one of several distances ranging from 0 to 6 m^{-1} for subjects *DY* and *FM*, and from 1 to 5 m^{-1} for *MB*. For all three subjects, the measured vergence (in degrees) was a linear function of the required vergence (in degrees or m^{-1}) with correlation coefficients >0.999 . Guided by projected target spots the subject then made a 10° centering saccade, and 50 ms later, to take advantage of postsaccadic enhancement (Busetini et al. 1997), the projected images were replaced with new ones so that the eccentricity of the individual dots on both retinas was increased (or decreased) by 4%. This required a system of feedback-controlled electronic shutters (General Scanning CX-660) and two additional projectors each with X/Y galvanometers and suitable polarizing filters. The radial flow here approximated that associated with a sudden 4% decrease (or increase) in viewing distance, except that the focus of expansion (or contraction) at each eye was always centered within $<1^\circ$ of the central fovea, regardless of the vergence angle, a situation that can arise under normal conditions only with very distant viewing. With forward motion, for example, before any compensatory eye movements, the focus of expansion normally lies directly ahead of each eye (in the direction of heading), and the two intersecting radial patterns of retinal flow generate binocular (crossed) disparity that is in inverse proportion to the square of the viewing distance (Howard and Rogers 1995). By positioning the focus of expansion always in the fovea on both retinas we avoided these changes in binocular disparity. Previous experiments had indicated that the size changes

that normally accompany changes in viewing distance are irrelevant for the generation of short-latency vergence responses by steps of radial flow (Busetini et al. 1997), and in the present experiments dot size did not change ("pure radial flow"). Because we were interested only in the initial vergence responses, the screen was blanked 200 ms after the radial-flow step, ending the trial.

To totally exclude any role for the slight optical distortions associated with changing the locations of the patterns on the tangent screen, we did additional experiments in which the radial-flow steps were seen by only one eye, arranging matters so that when the steps were applied both the focus of expansion/contraction and the viewing eye were always at the same (central) location on the screen. In these monocular control experiments, the changes in ambient vergence level were achieved by moving only one of the two images (asymmetrical vergence), which was then blanked as the eye viewing the other (stationary) image made a centering saccade guided by polarized target spots visible to that eye only. (In some experiments, the blanking was achieved with a shutter located at the projector, and in others with a shutter directly in front of the eye.) After the usual postsaccadic delay, the one visible (stationary) image was replaced by a new one so as to produce a radial-flow step with the focus of expansion/contraction always at the screen center where the fovea was already located. Thus regardless of the ambient vergence level, the locations of the focus of expansion/contraction and of the viewing eye did not vary; hence, any dependence of radial-flow vergence on the existing vergence

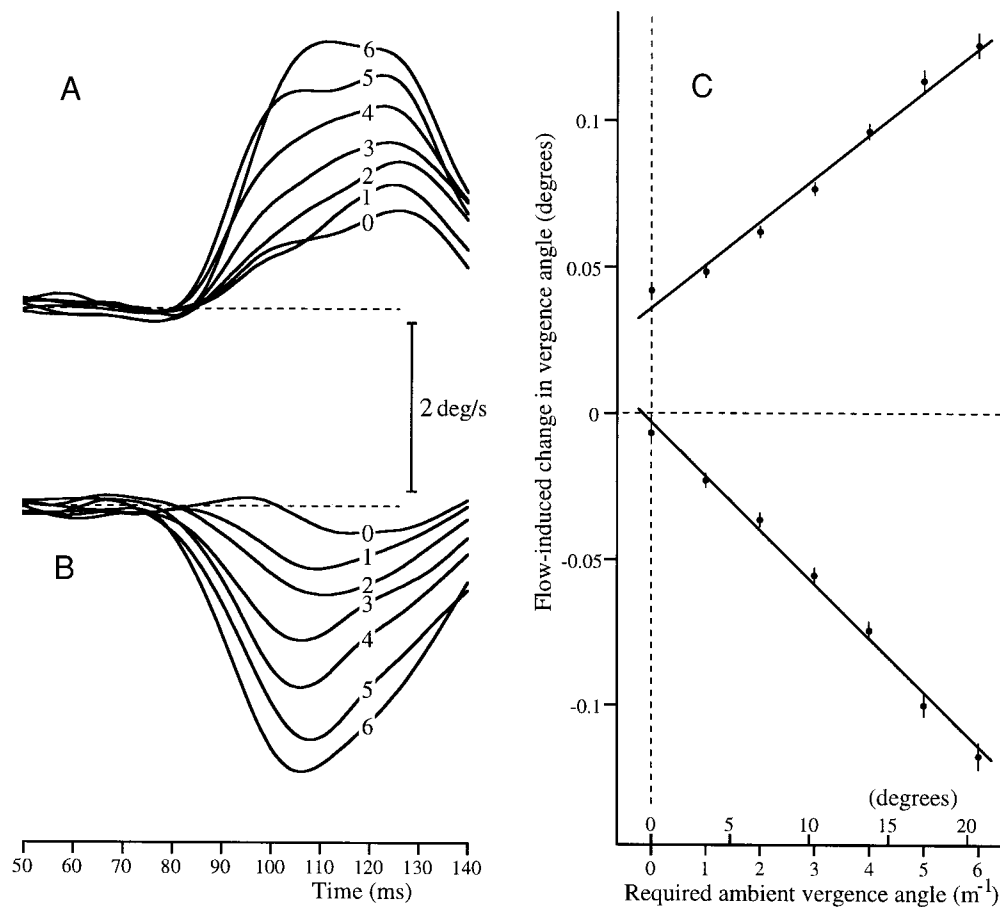

FIG. 1. Dependence of radial-flow vergence on the ambient vergence level. Mean vergence velocity responses (in $^\circ/\text{s}$) plotted against time (in ms) for expanding flow (A) and contracting flow (B). Numbers on traces: ambient vergence angle in m^{-1} . Upward deflections indicate increasing convergence. C: mean changes in vergence (in degrees—see METHODS) plotted against the ambient vergence angle (in m^{-1} and in degrees) for expanding (above) and contracting (below) flow. Means each based on data from 200–210 trials. Increases in convergence are positive. Error bars \pm SE. Data are from subject *DY*.

angle must result from the modulation of transmission in sensorimotor pathways. Each subject participated in several recording sessions, each stimulus condition being repeated 150+ times in a random sequence.

Vergence position was estimated by subtracting the horizontal position of the right eye from the horizontal position of the left eye, and vergence velocity was obtained by two-point backward differentiation. Mean vergence velocity profiles were calculated for each stimulus condition. To eliminate any effects caused by postsaccadic vergence drift, the mean vergence velocity profile recorded during the saccade-only control trials for each ambient vergence level was subtracted from the mean vergence velocity profiles during the test trials with the eyes at that same vergence level. The amplitude of the initial radial-flow vergence response was estimated by measuring the change in vergence position over a 50-ms time interval starting 90 ms after the onset of the radial-flow step. The mean change in vergence for all trials was then calculated, and again any effects caused by postsaccadic vergence drift were eliminated by subtracting the mean change in vergence during the control saccade-only trials.

RESULTS

As previously reported (Busetini et al. 1997), radial-flow steps induced transient vergence eye movements at latencies of 80–100 ms, expansions causing increases in convergence and contractions the converse. In all three subjects, increases in the ambient vergence angle resulted in clear increases in the vergence responses to radial flow steps. Sample data from one subject (DY) are shown in Fig. 1. The vergence velocity profiles in Fig. 1, A and B, indicate that the major effect of changing the preexisting vergence state was to re-scale the responses with only minor effects on the form and latency of the profiles. Note also that when the vergence angle was zero (as for an infinite viewing distance) the responses to contracting flow attenuated almost to zero, but there were still appreciable residual responses to expanding flow steps. This dependence on the vergence state is clear from the quantitative measures, which are plotted for the

same subject in Fig. 1C. The linear regressions for both sets of data in Fig. 1C have correlation coefficients >0.99, indicating that the vergence responses to steps of radial flow were a linear function of the vergence angle.

Very similar data were obtained from all three subjects. To facilitate quantitative comparisons and to indicate more clearly the magnitude of the impact of the ambient vergence state, the response measures for each subject were normalized by expressing them as a percentage of that subject's response when converged at 20 cm (5 m⁻¹). Table 1 lists the parameters for the least-squares regression lines of these normalized flow-induced vergence measures on the ambient vergence for all three subjects. Correlation coefficients were always >0.9, and the slopes for the contracting-flow data were higher than for the expanding-flow data. Further, intercepts were always appreciable with the expanding-flow, indicating residual responses with zero vergence.

Radial flow steps were still effective when applied monocularly, as previously reported (Busetini et al. 1997). Table 1 indicates that these monocularly induced vergence responses were sometimes weaker than with binocular stimulation (subject DY, and FM with expanding flow) but, perhaps surprisingly, sometimes stronger (subject MB, and FM with contracting flow): see the column labeled R₃, which lists the responses when the subjects were converged at the screen (3 m⁻¹). The vergence responses to monocularly presented radial-flow steps showed clear dependence on viewing distance in all three subjects, although this was sometimes significantly weaker than with binocularly presented steps (FM with contracting flow when the right eye was viewing, MB with expanding flow when either eye was viewing alone).

DISCUSSION

The data clearly indicate that the vergence responses to a constant 4% step of radial flow are directly proportional to the ambient vergence angle. The monocular data, which were

TABLE 1. Dependence of mean change in vergence on binocular fixation distance: linear regression analysis

Subject	Viewing	Expanding Flow				Contracting Flow			
		R ₃ degrees	Slope %/m ⁻¹	Intercept %	r _{xy}	R ₃ degrees	Slope %/m ⁻¹	Intercept %	r _{xy}
DY	Binoc	0.077	13.1	31.8	0.993	-0.056	18.7	3.0	0.996
	RE	0.063 (82%)	13.5	33.7	0.993	-0.050 (91%)	18.0	9.2	0.999
	LE	0.059 (77%)	13.9	29.0	0.997	-0.045 (81%)	19.5	4.2	0.997
	LE†	0.064 (83%)	13.1	31.9	0.994	-0.051 (92%)	16.3	19.2	0.995
FM	Binoc	0.079	14.5	25.0	0.985	-0.020	19.7	-1.1	0.938
	RE	0.040 (51%)	12.9	44.8	0.919	-0.036 (175%)	12.6	44.0	0.933
	LE	0.042 (53%)	13.5	35.8	0.993	-0.032 (155%)	18.8	8.7	0.996
	LE†	0.041 (52%)	12.0	48.8	0.915	-0.032 (155%)	17.6	16.9	0.987
MB	Binoc	0.078	16.8	16.4	0.997	-0.024	27.4	-37.2	0.998
	RE	0.120 (153%)	10.6	50.7	0.964	-0.042 (176%)	19.4	6.0	0.989
	LE	0.107 (137%)	8.8	59.5	0.958	-0.053 (219%)	18.2	12.2	0.988

Binoc, radial-flow steps seen by both eyes; RE, steps seen by right eye (shutter blanked left projector); LE, steps seen by left eye (shutter blanked right projector); LE†, steps seen by left eye (shutter blanked right eye); R₃, radial-flow-vergence response (measured as the change in vergence position, in degrees, over the period 90–140 ms from the onset of the stimulus) when the binocular stimuli were imaged in the plane of the screen at 3 m⁻¹; values in parentheses, R₃ response with monocular viewing expressed as a percentage of the R₃ response with binocular viewing. Slope, Intercept, and r_{xy} are the coefficients for the regression of mean change in vergence (expressed as a percentage of the responses when converged at 5 m⁻¹) on binocular fixation distance (in m⁻¹).

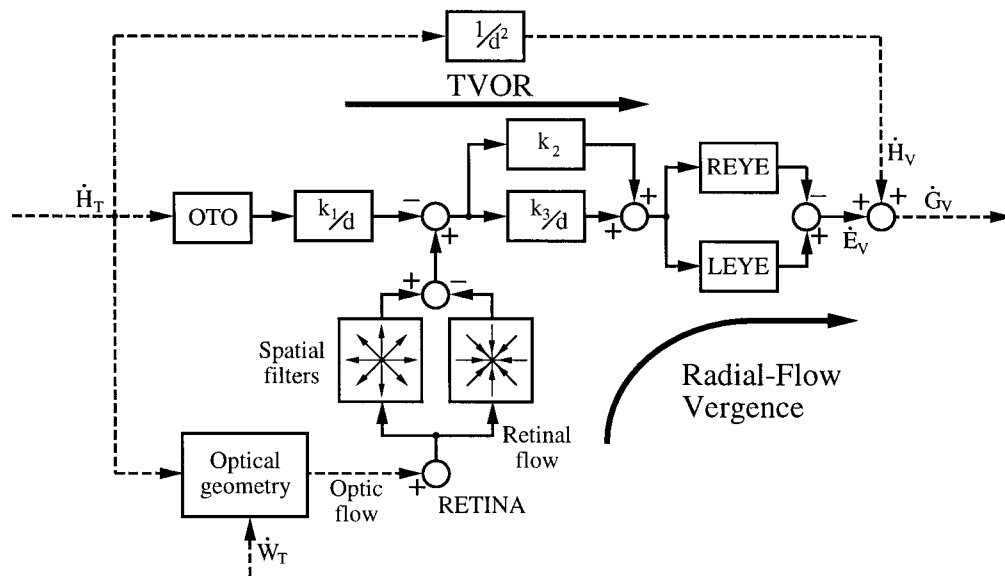

FIG. 2. Proposed linkage between the translational vestibulo-ocular reflex (TVOR) and the radial-flow vergence mechanism. TVOR is assumed to have an overall gain that is inversely proportional to the square of the viewing distance as required by the optical geometry, and this is achieved by two gain elements in series, each having a gain inversely proportional to viewing distance d . Radial-flow vergence affects gaze in inverse proportion to the viewing distance d and this is achieved by having the radial-flow input share the later part of the TVOR pathway. Side-path with a fixed gain k_2 accounts for the offset in the linear regressions, producing a component irrespective of proximity. For simplicity, responses to expansion and contraction are mediated by the same pathways, but the differences in their slopes and offsets suggest that the pathways might actually be different. Dashed lines represent physical links: \dot{H}_T and \dot{W}_T are translational velocity of head and visual surroundings, respectively; \dot{E}_V is the vergence velocity, \dot{H}_V is the vergence velocity required to offset the head translation, and \dot{G}_V is the vergence velocity error (gaze vergence velocity), all in angular coordinates. OTO, otolith organs.

obtained when these radial-flow steps were applied to a given eye while always at the same screen location, indicate that this dependence on the vergence angle cannot have been because of spurious optical effects and must reflect changes in the efficacy of transmission in sensorimotor pathways. If this relationship were to hold under normal viewing conditions, then these radial-flow-vergence responses would be proportional to the reciprocal of the viewing distance. What could be the functional benefit of attenuating the sensitivity to radial flow with distant viewing? As pointed out earlier, to maintain binocular alignment during fore-aft movements, vergence must change at a rate (in degrees of vergence eye movement per cm of head translation, for example) that is a function of the square of the vergence angle. Thus as fixation distance increases and vergence goes to zero, the changes in vergence required to maintain binocular fixation with fore-aft movements also go to zero. This means that when a moving observer looks far ahead in the direction of heading, any tendency for the optic flow created by nearby objects to converge the eyes would compromise binocular fixation. Hence, the utility of reducing the sensitivity to radial flow as the fixation distance increases.

Under normal conditions, radial optic flow results from motion of the observer that would also engage the translational vestibulo-ocular reflex (TVOR), an otolith-driven mechanism, which with fore-aft motion, generates vergence responses that are also a function of the preexisting vergence angle (Paige and Tomko 1991). In fact, the data of Paige and Tomko suggest that the gain of the fore-aft TVOR is proportional to the square of the vergence angle as required by the optical geometry, although these workers did not

attempt to fit such a function to the data. We suggest that radial-flow vergence and the TVOR operate synergistically during fore-aft accelerations to maintain binocular alignment on objects in the scene ahead and share a pathway whose gain modulates with vergence angle. That the "gain" of the visually driven vergence eye movements varies directly with the ambient vergence state, whereas the gain of the TVOR probably varies with the square of the ambient vergence, might be explained if the TVOR pathway has two gain elements in series, each being a function of the ambient vergence level, the radial-flow input entering between them. Figure 2 shows a block diagram of the proposed arrangement with the dependence on vergence being depicted in reciprocal units, k_1/d and k_3/d , where d is the viewing distance. In the model, the radial flow signals are extracted by spatial filters such as those postulated to be in the dorsal stream of cortex (Perrone and Stone 1998). Similar evidence for a synergy between visual and vestibular mechanisms with shared pathways whose gain modulates with viewing distance has been presented for the ocular following and TVOR mechanisms that generate conjugate (version) eye movements to compensate for lateral and vertical accelerations of the head (Busettini et al. 1991, 1994). The general implication is that visual and vestibular mechanisms work in close synergy, even sharing central pathways, to help stabilize gaze during translational disturbances of the observer in any direction.

We thank Dr. Lance M. Optican for help with the optical geometry and for suggesting that the dependence of the translational vestibulo-ocular reflex on vergence results from two cascaded elements.

Address for reprint requests: F. A. Miles, Laboratory of Sensorimotor Research, National Institutes of Health, Bldg. 49, Rm. 2A50, 49 Convent Dr., Bethesda MD 20892-4435.

Received 26 May 1998; accepted in final form 2 October 1998.

REFERENCES

- BUSETTINI, C., MASSON, G. S., AND MILES, F. A. Radial optic flow induces vergence eye movements with ultra-short latencies. *Nature* 390: 512–515, 1997.
- BUSETTINI, C., MILES, F. A., AND KRAUZLIS, R. J. Short-latency disparity vergence responses and their dependence on a prior saccadic eye movement. *J. Neurophysiol.* 75: 1392–1410, 1996.
- BUSETTINI, C., MILES, F. A., AND SCHWARZ, U. Ocular responses to translation and their dependence on viewing distance. II. Motion of the scene. *J. Neurophysiol.* 66: 865–878, 1991.
- BUSETTINI, C., MILES, F. A., SCHWARZ, U., AND CARL, J. R. Human ocular responses to translation of the observer and of the scene: dependence on viewing distance. *Exp. Brain Res.* 100: 484–494, 1994.
- HAYS, A. V., RICHMOND, B. J., AND OPTICAN, L. M. A Unix-based multiple process system for real-time data acquisition and control. *WESCON Conf. Proc.* 2: 1–10, 1982.
- HOWARD, I. P. AND ROGERS, B. J. In: *Binocular Vision and Stereopsis*, Oxford 1995, p. 37.
- PAIGE, G. D. AND TOMKO, D. L. Eye movement responses to linear head motion in the squirrel monkey. II. Visual-vestibular interactions and kinematic considerations. *J. Neurophysiol.* 65: 1183–1196, 1991.
- PERRONE, J. A. AND STONE, L. S. Emulating the visual receptive-field properties of MST neurons with a template model of heading estimation. *J. Neurosci.* 18: 5958–5975, 1998.